

PERSPECTIVE

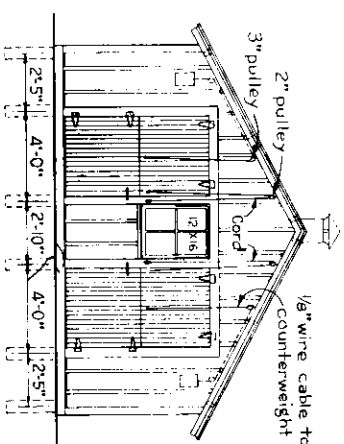

SOUTH ELEVATION  
Scale 1/4" = 1'-0"

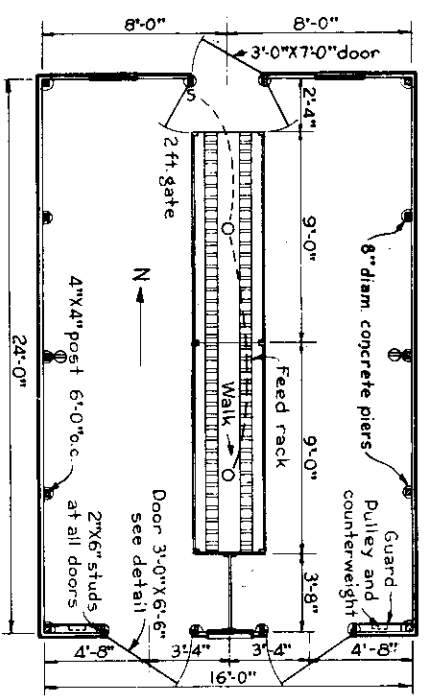

PLAN  
Scale 1/2" = 1'-0"

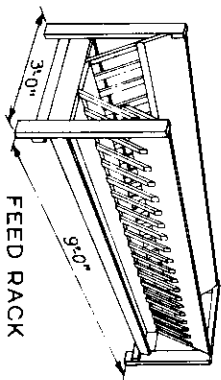

FEED RACK

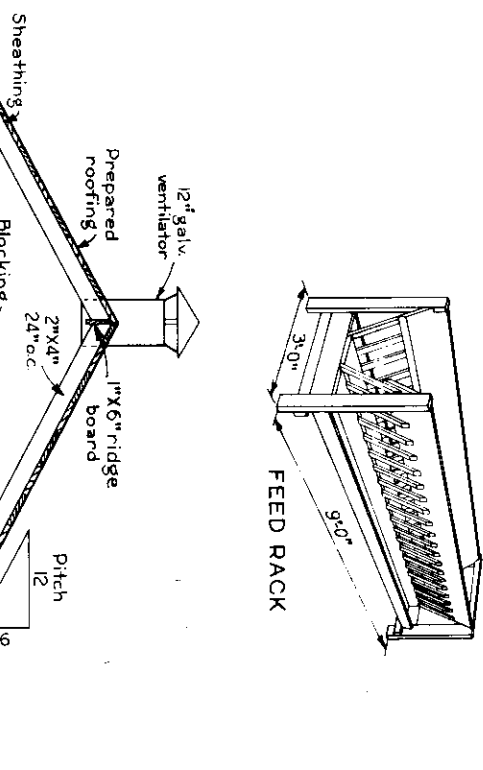

- CONCRETE**  
3 sacks cement 9cu. ft. sand 15cu. ft. gravel
- LUMBER**
- 5-4"x4"x12'-0"
  - 5-2"x4"x14'-0"
  - 2-2"x4"x12'-0"
  - 2-2"x4"x16'-0"
  - 26-1"x12"x12'-0"
  - 8-1"x6"x12'-0"
  - 5-1"x4"x10'-0"
  - 220-lin. ft. 1"x2" T & G flooring (doors)
  - 200-lin. ft. 1"x4" T & G flooring (roof)
- MISCELLANEOUS**
- 6-squares roofing
  - 32-bolts 1/2"x4 1/2"
  - 5-hasps
  - 8-2" pulleys with hooks
  - 30-lin. ft. 1/8" wire cable
  - 16-pieces strap iron 1/2"x1/2"x18"
  - 8-lbs. 6d nails
  - 12-lbs. 16d nails

**BILL OF MATERIALS**

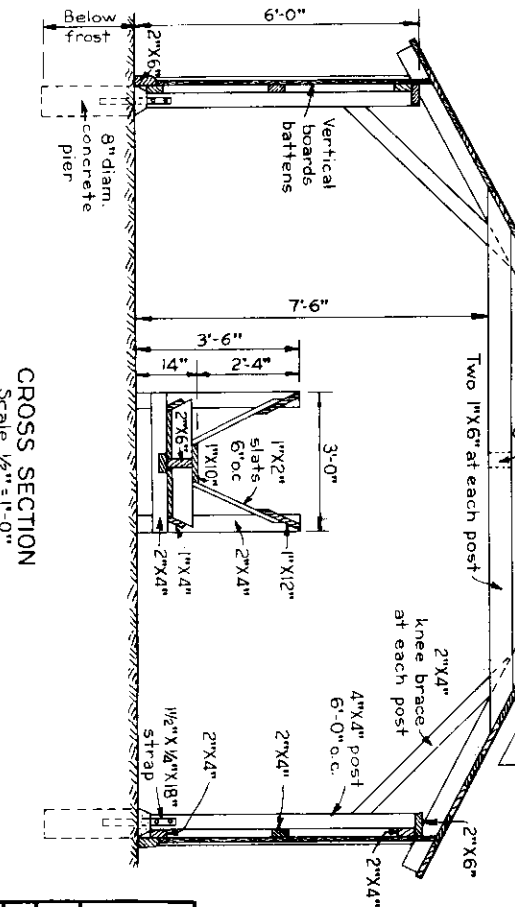

SECTION OF SOUTH DOOR  
Scale 3/4" = 1'-0"

CROSS SECTION  
Scale 1/2" = 1'-0"

COOPERATIVE EXTENSION WORK IN  
AGRICULTURE AND HOME ECONOMICS  
STATE OF NORTH DAKOTA  
NORTH DAKOTA AGRICULTURAL COLLEGE  
UNITED STATES DEPARTMENT OF AGRICULTURE COOPERATING

**SHEEP SHED**

USDA	EX. 5019	SHEET 1 OF 1
------	----------	--------------