

HEAD RAIL OPTIONS

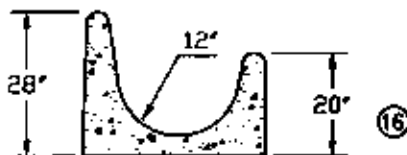
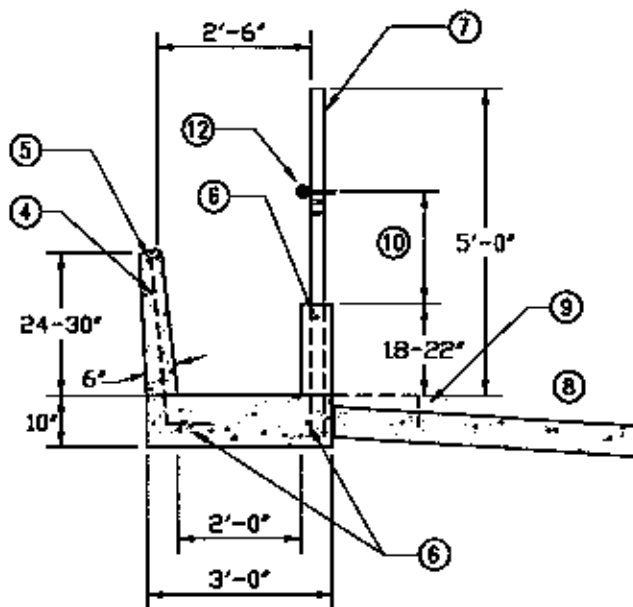

1. pipe & plank bunk option
2. concrete bunk options
3. 2" plank
4. 10M vert rebar 18" oc
5. 10M horiz rebar
6. 15M horiz rebar
7. 3" steel post 6' oc
8. 5-6" concrete apron, slope 3%
9. 12" x 5" step, optional
10. height variable: 16"-22"
11. 2" pipe or double angle iron
12. 1/2" cable in eyebolt
13. pipe on steel brackets
14. 2 x 8 rough plank
15. highway guard rail section
16. slip formed concrete

Designed: D.D./O.K.
 Drawn: D.D.
 Date: 1995-09 R97/04
 File name: FEEDBUNK

Plan

FEED BUNKS

Sheet of

Alberta
 AGRICULTURE
 Engineering Services